

Switzerland +

Precision end cutters

ideal-tek  
SWISS TECHNOLOGY AT YOUR FINGERTIPS



ISO 13485  
BUREAU VERITAS  
Certification



ISO 9001  
BUREAU VERITAS  
Certification



## Precision End Cutters

Ideal-tek precision end cutters are popular for fine mechanical work including watchmaking and repair. These cutters are tough enough for difficult jobs, ideal for working in confined spaces and for cutting hairsprings and soft metals.

### BENEFITS

- Perfect joint alignment
- Non-slip textured handles
- Double-leaf springs to reduce fatigue
- No “slack” or “play”
- Lightweight

### FEATURES

- AISI 420A Stainless Steel
- Monocomponent handles
- Lap Joint
- 60-62 Rockwell Hardness (HRC)

### Maintenance

In order to preserve your cutters perfectly efficient keep a thin oil film on the tip head.

# Dimensions

End cutters - pointed head

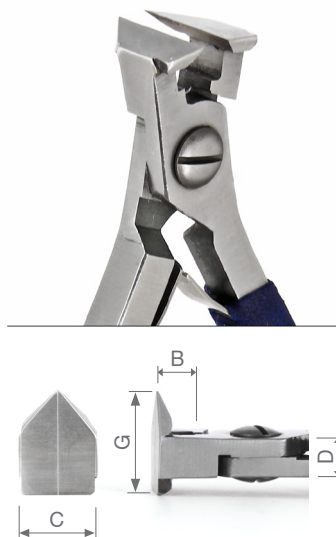

Oblique End cutters - pointed head

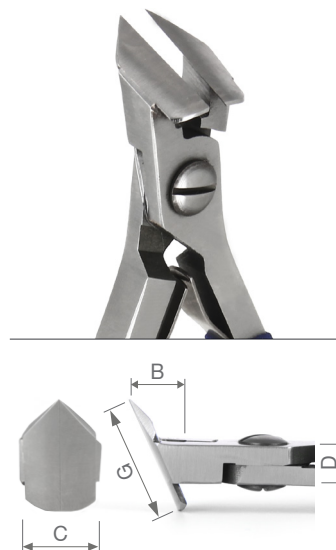

End cutters - double pointed head

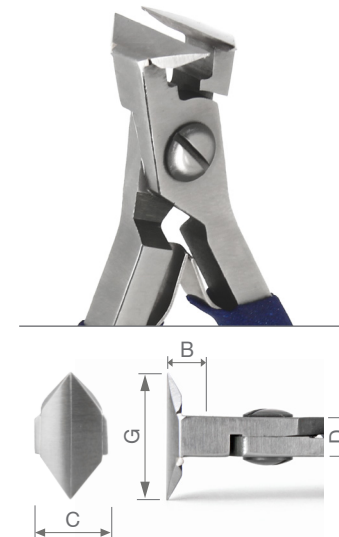

Art. No.	Type	OAL[mm]	B[mm]	C[mm]	D[mm]	G[mm]
<b>16.CR.BL</b>	Pointed Head	115.0	6.0	11.5	6.4	16.0
<b>17.CR.BL</b>	Oblique pointed Head	120.0	8.5	11.5	6.4	19.5
<b>17C.CR.BL</b>	Oblique pointed Head	110.0	8.5	11.5	6.4	19.5
<b>20.CR.BL</b>	Double pointed Head	115.0	6.0	11.5	6.4	20.0

**Mail address**

Ideal-tek SA · p.o. box 17  
6830 Chiasso · Switzerland

**Shipping address**

Ideal-tek SA · via Motta 4  
6828 Balerna · Switzerland

**Phone** +41 91 683 32 29

**Fax** +41 91 683 03 71

**E-mail** [info@ideal-tek.com](mailto:info@ideal-tek.com)

**Web** [www.ideal-tek.com](http://www.ideal-tek.com)



 ideal-tek  
SWISS TECHNOLOGY AT YOUR FINGERTIPS